

SEA FROST SHORE ASSIST SA-II 134a

THIS MANUAL IS SUPPLEMENTAL TO THE SEA FROST R-134a ENGINE DRIVE MANUAL.

INSTALLATION INSTRUCTIONS

CONDENSING UNIT LOCATION AND MOUNTING

The design of the Shore Assist allows placement of the air-cooled unit in an enclosed space such as a cabin locker, sail locker or engine room. Intake air should be drawn in from the cabin area to insure the coolest, driest air supply. Standard 4" duct hose may be used. Discharge does not need ducting if a vent in the area allows warm air to escape. Intake ducting from the exterior of the boat will cause damp salt air to be drawn in reducing unit life. This will also increase below deck moisture. Unlike the standard SA-I, the SA-II has a higher noise level. Please consider this when locating the SA-II in the cabin area.

An unducted SA-II in a poorly ventilated small space will heat the air, lowering the capacity of the unit and possibly causing damage by overheating the compressor.

Service access and installation requires that the front and left end (inlet/outlet side) be exposed. The duct hose will require 4 inches of clearance past the end of the unit.

Mount the Shore Assist level. The compressor is at the bottom. The unit may be bulkhead or platform mounted. Pilot holes have been predrilled for the #8 x 3/8" self-taping screws and aluminum angle clips, included with the system.

INSTALLATION REQUIREMENTS

- ❖ Neither inlet nor outlet should ever be blocked.
- ❖ Provide for driest, coolest air for intake (top air port on housing.)
- ❖ Total combined air duct length for intake and discharge should not exceed six feet.

❖ Only the intake needs ducting if the area is vented to allow warm discharge to escape.

❖ For intake or exhaust through a finished panel, order an extra black flange grill. One part is shipped with each system.

BEFORE BEGINNING THIS SECTION READ; "WORK HABITS", "TUBE HANDLING", "CUTTING and BENDING", and "SWAGELOK FITTINGS" in the SEA FROST ENGINE DRIVE INSTALLATION MANUAL.

EXPANSION VALVE.

Install the valve to supply one of the 3/8-inch tubes from one of the plates. The valve may supply either plate first in a two-plate series system but the thermostat sensing bulb should be on the second plate. If the system is a three-plate freezer/fridge, install the valve to supply one of the freezer plates, Attach the thermostat sensing bulb to the refrigerator plate.

The valve should be located to allow access to the screw cap on top of the valve. It is preferable that the cap be up.

Trim the tube ends on the plate as necessary. However, allow at least 3/4" to insert into the fitting. Refer to the Swagelok installation instructions.

INTERCONNECTING JUMPER

The SA-II system is connected in series. Connect a 3/8" tube between the first plate and the second and, between the second and third refrigerator plate if applicable.

THE RECEIVER FILTER DRIER (RFD)

Note: Unpack and fit the RFD last and at the time of evacuation and charging to prevent saturating the desiccant with moisture.

Mount the RFD external to the SA-II cabinet, connecting to the 1/4" liquid line. It must be mounted vertically with the fittings at the top. It is fitted with a sight glass for checking the charge. This glass is best viewed looking straight into the top. **Install the RFD in a location that allows proper viewing of the sight glass.** The RFD must be installed in the proper flow direction. Connect the tube from the compressor to the in side of the RFD. The out connects to the tube that connects to the valve.

RUNNING TUBING LINES

Two lines connect the plates and the compressor. The return line is 3/8" and the liquid line is 1/4".

Run the 1/4" liquid line between the SA-II and the expansion valve. This 1/4" line connects to the expansion valve. The externally mounted receiver filter drier (RFD) will be fitted to this line. See: RFD. The 3/8" line connects to the last plate in the series with a 3/8" fitting. The other end of this 3/8" line connects to the compressor.

Run the 1/4" liquid line in contact with 3/8" suction line for at least one foot from the refrigerated cabinet. Wrap these two tubes tightly together with electrical tape. Insulate this section. This will improve operation and prevent moisture from condensing on the coldest section of these tubes. It is not necessary to insulate the remaining length of 3/8" return line to the compressor.

CAP TUBE ENDS

Be sure to keep each tube end capped with the plastic caps after each cut on both the piece used and the coil.

Support the tubing every 18 inches as necessary with tie wraps and self taping screws.

WARNING:

<p>The SA-II unit is shipped with some nitrogen pressure. Before removing the caps on the Swagelok fittings remove the plastic caps on the service valve covers and depress the valve cores to vent any existing pressure.</p>

COMPRESSOR CONNECTIONS

Working one line at a time, remove the Swagelok caps from compressor and condenser fittings. Attach the union fitting bodies. This is a pre-swaged connection; see the Swagelok fittings text in Engine Drive installation manual. Make up of these pre-swaged connections is 1/4 turn from wrench snug. Connect the 1/4" copper line to the condenser fitting and 3/8" copper line to the compressor. Tighten these fittings 1-1/4 turns from *wrench snug*. (See to the Swagelok text in Engine Drive manual).

THERMOSTAT

For the best looking job the thermostat should be recessed into a panel. A cutting template is provided. Locate the thermostat close enough for the bulb on the sensing tube (pig tail type coil) to reach a mounting ear on the second plate in a two-plate system or the refrigerator plate in a three-plate system. It is necessary that the bulb end of the sensing tube be in excellent thermal contact with the plate. Attach the bulb to the plate using the stainless steel clip. Use one of the existing plate mounting screws as an attachment point.

The sensing tube is hollow; avoid bending or kinking it.

WIRING

The thermostat electrical leads are low voltage for safety. Connect the thermostat red wires to the red wires exiting the compressor unit. There is no polarity requirement.

110-VOLT CIRCUIT

A separate 15-amp breaker is required for the 110-volt supply. The Shore Assist is provided with a 3 wire male plug. A standard **dedicated** receptacle mounted next to the unit is recommended. Secure all wiring as necessary.

COMMISSIONING

Attach clean, purged gauges to the suction service port on compressor. This is the blue-capped tube stub on the compressor. It is not necessary to connect to the high-pressure port when starting a new system. This is provided to aid in fault diagnosis.

Check for leaks. Refer to the Engine Drive instruction manual: Refrigerant Handling and Leak Checking sections.

After checking for leaks, evacuate. Pump down to the best vacuum.

CHARGE

This system operates with refrigerant R-134a. The MAXIMUM charge amount is 12 oz.

 **WARNING!** Do not use refrigerant with any additives, including but not limited to: oil, dye, and leak stop.

This may be liquid-fed into the low side after evacuation, before the compressor is operated. An automatic expansion valve regulates the evaporator pressure. This valve is adjusted to maintain a constant evaporator pressure. The proper charge must be added before the valve can be accurately set.

ADJUSTING THE VALVE

Before operating the compressor, unscrew the plastic cover on the valve body. Note the adjusting knob. Counter-clockwise rotation decreases the pressure. Clockwise rotation increases the pressure. One turn should equal a 2 psi pressure change. Check that the valve is set with the last groove even with the end of the valve body.

Start the compressor. The valve must be adjusted to a 0 to 2 psi reading on the low side gauge port. Be sure your gauge is set at 0 before hook-up. Allow several minutes between each adjustment. Moisture may form on the adjusting knob side of the valve and freeze causing the valve to malfunction. To prevent this replace the cap after each adjustment. Be sure the valve is dry before final cap replacement. Operate for 30 minutes to confirm proper valve setting and operation.

The valve may need to be cleared of dirt or chips if adjustment is not possible. With the compressor running, turn the valve adjustment knob clockwise about 3 turns momentarily, and then back to the proper setting. Do not leave the valve in open position allowing high backpressure, as this may cause the compressor to overload.

After satisfactory adjustment, turn off the thermostat and remove the gauges. If the high side gauge is connected, wait until the pressure equalizes on both gauges before removal. Recap the service ports and replace the SA-II cover. When the valve has dried, insulate the valve body by cutting the insulating sleeve to fit the valve then wrap with cork tape to prevent condensation. Insulate the one-foot section of 3/8" tubing that exits the refrigerated cabinet. The valve need not be insulated if it is in the icebox.

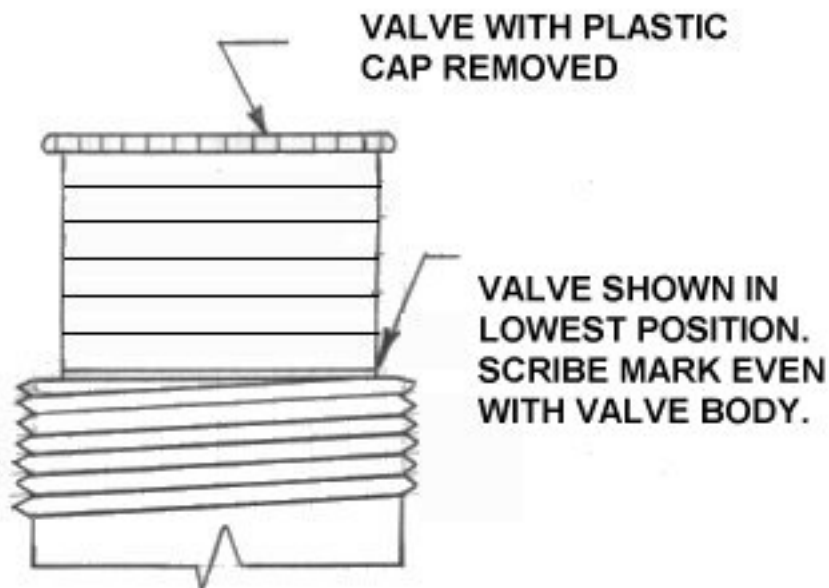

Troubleshooting note: The operating pressure of the system **will not** indicate the amount of refrigerant in the system. The valve will not give proper operation or pressure if it is undercharged. Check the valve scribe line. It should correlate to gauge pressure.

The system requires enough refrigerant to supply liquid to the valve. If the valve has a steady hissing sound then the charge is ok. If the valve is sputtering then it is low. If the valve is making a noticeable roar it is empty. If the low side pressure is properly set the high side pressure will be 80 to 135 psi depending on the air temperature (50 to 95 degrees F.) through the unit. Almost immediately upon start up the valve body will begin to frost.

THE THERMOSTAT

The Shore Assist thermostat is variable. Turning the knob fully counterclockwise turns the unit "OFF". The one snowflake position is the warmest setting. The fully clockwise setting at three snowflakes is the coldest. The thermostat may be adjusted to obtain any temperature desired in the cabinet and may be calibrated should the warmest setting be too cold. See THERMOSTAT CALIBRATION INSTRUCTIONS ATTACHED.

OPERATION DESCRIPTION

The SEA FROST Shore Assist SA-II is a small system. It is efficient in its electrical conversion of energy to heat movement. Its rate of cooling is 1/15 the rate of the Engine Drive system. By being small it is quiet, compact, has low electrical starting requirements and running power draw and is able to be air-cooled. The SA-II will operate in up to 120 degrees of ambient air temperature. Because of its size it will operate 80 percent of the time in warm climates. The unit will freeze the holdover plates from warm but may take all day. If rapid cooling of the system is needed operate the Engine Drive to bring the system to its cooling temperature then let the SA-II take over. The unit will automatically operate if the thermostat, and proper panel switch is on and shore power is available. The system may be operated using the proper sized DC to AC inverter. The Shore Assist and the Engine Drive are separate units and may be operated simultaneously; both units are controlled by separately.

DEFROSTING

The plates will require defrosting from time to time as the frost layer builds up.

Allowing the plates to warm above freezing is one method of defrosting. Warm water or a hair dryer is also a quick method. The SEA FROST plates can be scraped with a spatula or ice scraper to remove excessive frost build up.

OPERATION INSPECTION

Within a few minutes of starting the Shore Assist the tubing in close proximity to the valve and the valve itself will be noticeably cold. **After 20 minutes of operation if cooling in this area is not observed do not continue to operate the system.**

The first plate in the system will cool first. Because it is first to freeze, all the moisture suspended in the air within the cabinet will condense and freeze on the first plate. The amount of frost on the plates is not a good indication of proper operation. Spill some water on the second (or third plate if fitted) to see if it freezes.

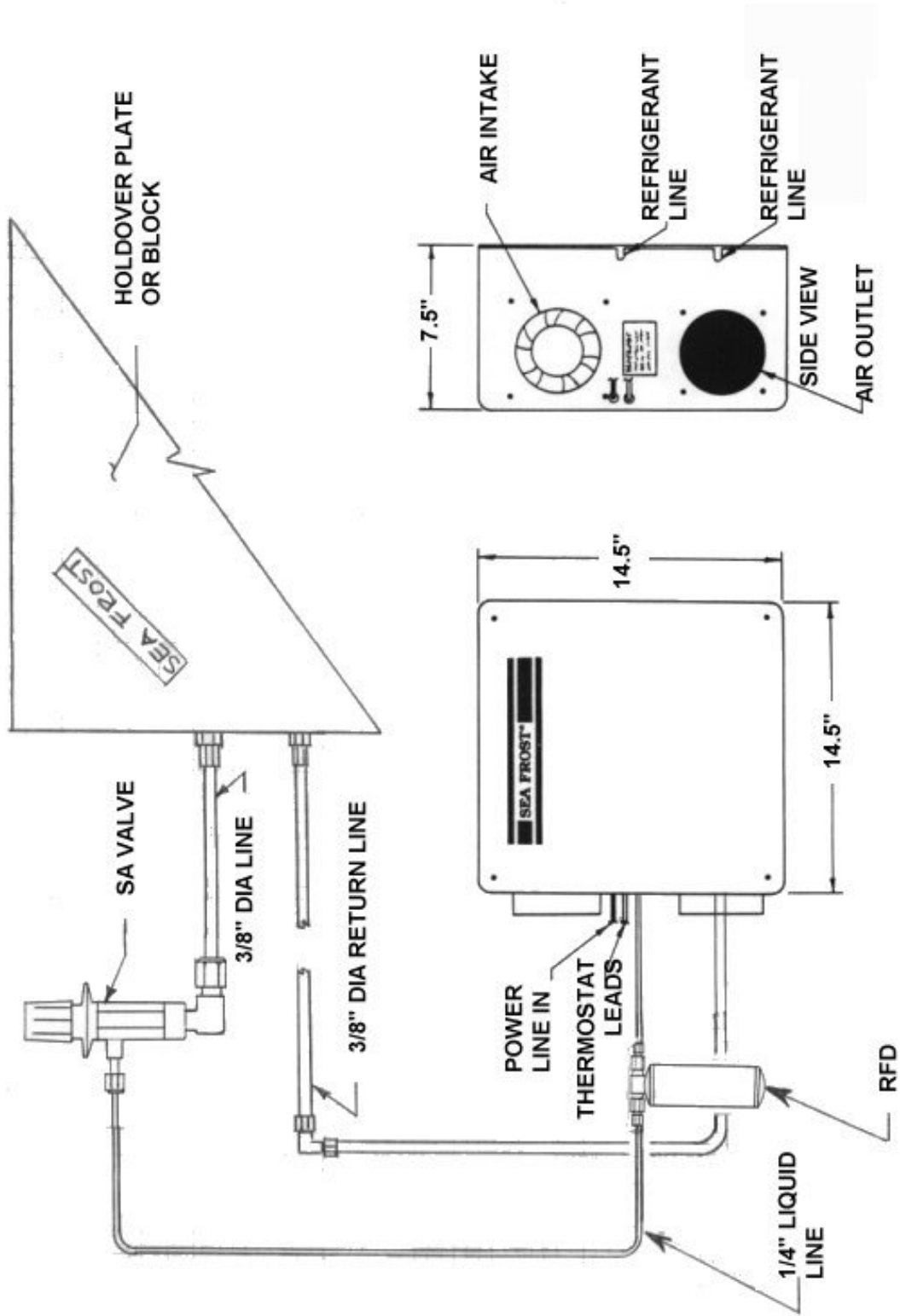

SHORE ASSIST VALVE SCHEMATIC

THERMOSTAT CALIBRATION INSTRUCTIONS

Note: Be sure that the unit is operating properly before making any thermostat adjustments. The sensing bulb must be in excellent thermal contact with the plate or block.

The range of this control may be changed. To access the adjustment screw, remove the four mounting screws on the thermostat panel. Tip the panel forward and remove the protective tape to expose a slot in the case. Make the adjustment with a number torx or small phillips head screwdriver.

Make small adjustments. Record all adjustments.

If the lowest setting on the thermostat panel (1-snowflake) is too cold:

- Turn the adjustment screw clockwise. One 360-degree turn will raise the box temperature approximately 6 degrees f.

If the highest setting on the thermostat panel (3-snowflakes) is too warm:

- Turn the adjustment screw counterclockwise.

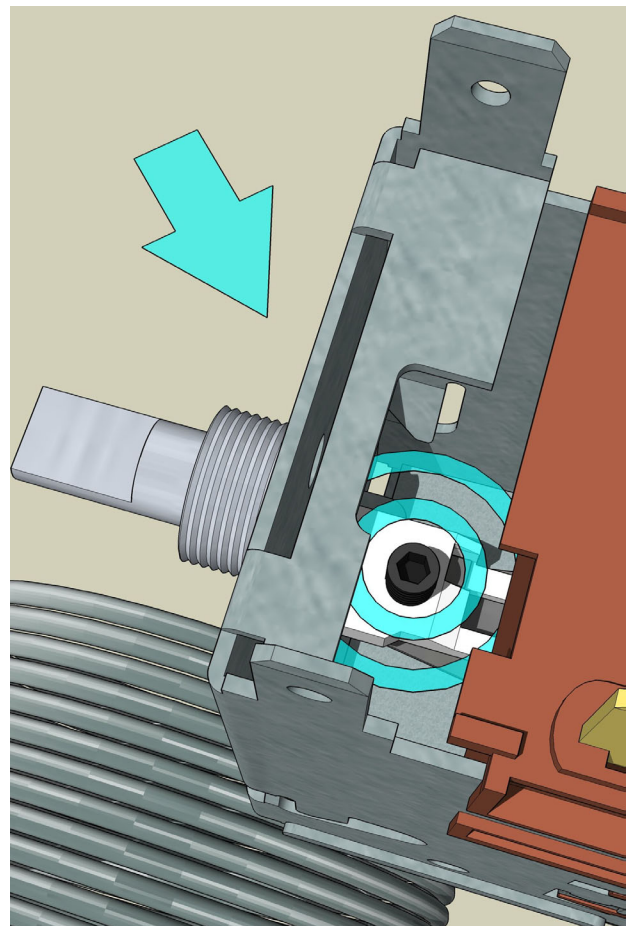

HOLDOVER PLATES

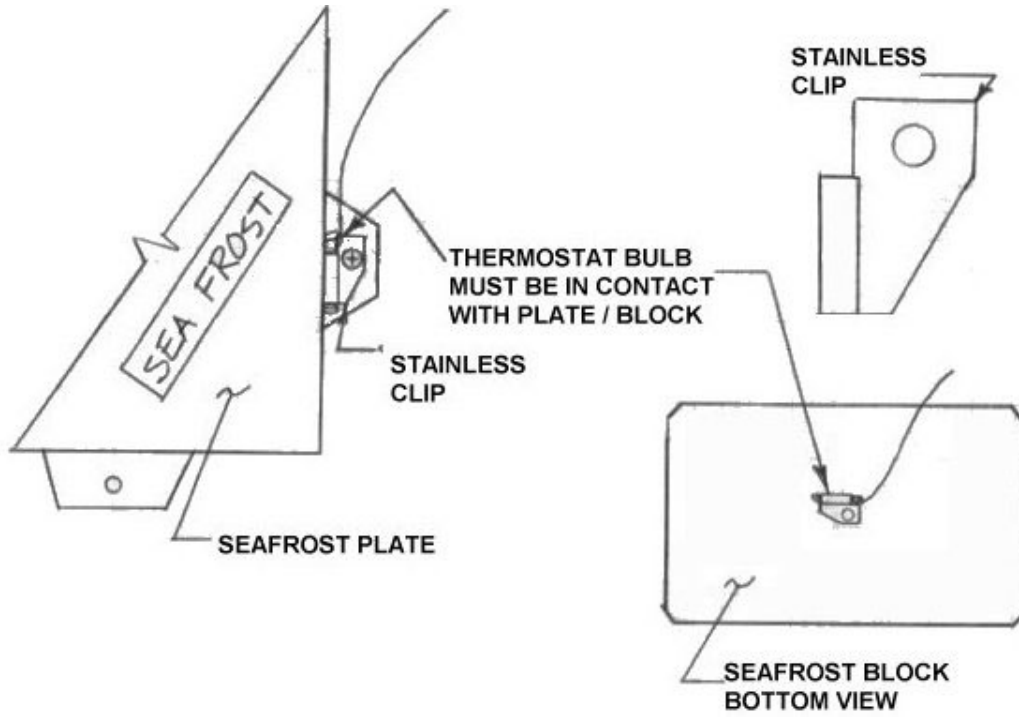

STAINLESS STEEL EVAPORATOR PLATES

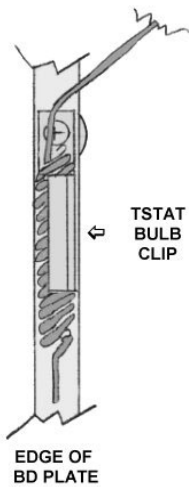

THERMOSTAT MOUNTING TEMPLATE

CUT OUT